



PIPseq™ V T100 3' Single Cell RNA Kit

User Guide

For use with the PIPseq V T100 3' Single Cell RNA Kit Bundle which contains:
PIPseq V T100 Capture & Barcoding Kit, FB0005359
PIPseq V Library Prep Kit, FB0005372

Doc ID: **FB0005262**

Revision: **1.5**

State: **Release**

Table of Contents

1. Introduction	4
1.1. Protocol Timing	4
1.2. PIPseq Platform Overview	5
1.2.1. PIPseq V T100 3' Capture and Barcoding Kit	5
1.2.2. PIPseq V Universal Starter Equipment Kit	6
1.2.3. PIPseq V T100 3' Capture & Barcoding Consumables Kit	6
1.2.4. PIPseq V T100 3' Capture & Barcoding Ambient Kit	7
1.2.5. PIPseq V T100 3' Capture & Barcoding -20°C Kit	7
1.2.6. PIPseq V T100 3' Capture & Barcoding -80°C Kit	7
1.2.7. PIPseq V Library Prep Kit	8
1.2.8. PIPseq V Library Prep Ambient Kit	8
1.2.9. PIPseq V Library Prep -20°C Kit	8
1.3. Third Party Reagent, Equipment and Consumable Requirements	8
1.3.1. Required Third Party Reagents	8
1.3.2. Required Third Party Consumables	9
1.3.3. Required Third Party Equipment	10
1.3.4. PIPseq-Compatible Alternative RNase Inhibitors	10
1.4. Guide to Protocol Notes	11
2. Best Practices	11
2.1. Working with RNA	11
2.2. Working with PCR Products	12
2.3. Centrifuge Steps	12
2.4. Thermocycler Lid Pressure	12
2.5. Cell Loading	13
3. PIPseq Equipment Preparation	13
3.1. PIPseq Vortexer Operation	13
3.2. PIPseq Dry Bath Operation	14
3.2.1. PIPseq Dry Bath	14
3.2.2. PIPseq Dry Bath Lid Settings and Control	14
3.2.3. PIPseq Dry Bath Control	14
3.2.4. PIPseq Dry Bath Protocols	15
4. Sample Preparation	16
4.1. Cell Preparation	16
4.1.2. Working with Fixed Cells	18
4.2. Nuclei Preparation	19
4.2.1. Nuclei Isolation	19
4.2.2. Working with Fixed Nuclei	20
4.2.3. Nuclei Suspension Buffer Preparation	20
5. PIPseq V T100 Protocol	21
5.1. Capture and Lysis	21

5.2. mRNA Isolation	26
5.2.1. Reagent Preparation	26
5.2.2. Breaking Emulsions	26
5.2.3. Washing PIPs with 1X Washing Buffer	29
5.3. cDNA Synthesis	30
5.3.2. Reverse Transcription	30
5.3.2. Washing PIPs with 0.5X Washing Buffer	31
5.4. cDNA Whole Transcriptome Amplification	32
5.5. Isolate cDNA from PIPs	33
5.5.1. cDNA Isolation	34
5.5.2. Magnetic Bead Purification	34
5.6. cDNA QC	36
5.6.1. cDNA Amplification for QC	36
5.6.2. cDNA Isolation for QC	37
5.6.3. Qubit Quantification	39
5.6.4. Fragment Analysis	39
5.7. Library Preparation	40
5.7.1. Fragmentation, End Repair & A-Tailing	40
5.7.2. Adapter Ligation	42
5.7.3. Post Ligation Cleanup	43
5.7.4. Sample Index PCR	44
5.7.5. Post Sample Index PCR Cleanup (one-sided)	45
5.8. Post Library Preparation QC	46
5.8.1. Qubit Quantification	46
5.8.2. Fragment Analysis	46
6. Sequencing	47
6.1. Library Structure	47
6.2. Recommended Sequencing Depth	47
6.3. Sequencer Compatibility	47
6.4. Pooling for Illumina Sequencers	48
6.5. Informatics Analysis	48
6.6. PIPseq 3' Index Sequences	49
7. Appendix I - PIPseq Replay with the SEA Kit	49
8. Appendix II - Oligonucleotide Sequences	50
9. Appendix III - Abbreviations	50
10. Appendix IV - Troubleshooting	51
11. Document Revision Summary	52
12. Legal Notices	52
Support	52

1. Introduction

The Fluent BioSciences PIPseq™ V T100 3' Single Cell RNA Kit uses Particle-templated Instant Partitions (PIPs) to combine single cell or nuclei suspensions with barcoded beads to produce sequencing-ready libraries in less than 2 days. This kit is configured with 2 individual reactions, in which up to 100,000 cells or nuclei can be profiled per reaction. Sequencing data can be processed through PIPseeker™, a comprehensive analysis solution that provides users with detailed metrics, gene expression profiles, basic cell quality, and clustering. The “Getting Started with PIPseeker tutorial” can be downloaded at <https://www.fluentbio.com/products/pipseeker-software-for-data-analysis/>.

1.1. Protocol Timing

Stage	Steps	Duration	Stopping Point	~Hands On Time
mRNA Capture	Reagent Preparation	~30 min		~2 hrs
	General Cell Preparation (user cell type dependent)	~1-1.5 hrs		
	Capture and Lysis	1 hr 40 min	20°C for up to 96 hrs	~10 min
	mRNA Isolation Breaking Emulsions Washing PIPs with 1X Washing Buffer	15 min 30 min		~45 min
cDNA Preparation	cDNA Synthesis Reverse Transcription Washing PIPs with 0.5X Washing Buffer	2 hr 30 min 30 min	4°C overnight	~30 min
	cDNA Whole Transcriptome Amplification	1 hr	4°C overnight	
	Isolate cDNA from PIPs cDNA Isolation Magnetic Bead Purification	20 min 30 min	PIPs pellet -80°C cDNA -80°C <72 hrs	~50 min
	cDNA QC and Quantification QC PCR Magnetic Bead Purification Quantification & Fragment Size Analysis	1 hr 20 min 30 min 20 min		~30 min
	Library Preparation Fragmentation, End Repair & A-Tailing Adapter Ligation Post Ligation Cleanup Sample Index PCR	50 min 30 min 20 min 1 hr	4°C overnight	~2 hrs
Library Preparation	Post Sample Index PCR Cleanup	30 min	-20°C long-term	~30 min
	Post Library Preparation QC Quantification & Fragment Size Analysis	25 min		

1.2. PIPseq Platform Overview

The PIPseq V T100 3' Single Cell RNA workflow requires a reagent kit for single cell capture and barcoding, a library preparation kit for preparing sequencing-ready libraries, and a starter kit containing required equipment. The PIPseq V T100 3' Capture & Barcoding Kit consists of three reagent kits (Ambient, -20°C and -80°C) and a Consumables kit. Users planning to prepare libraries for short-read sequencing should purchase the PIPseq V Library Prep Kit. All PIPseq kits require a single-purchase Starter Equipment Kit containing the required equipment to run the workflow. Be sure to review and store reagents at appropriate temperatures according to instructions below.

Storage requirements upon receiving the PIPseq V T100 3' Single Cell RNA kit:

Remove the Capture & Barcoding -80°C Kit containing the TSO aliquots (FB0005109) and PIP tubes (FB0005097) from the dry ice shipping container and store at -85°C to -75°C.

Remove the Breaking Buffer (FB0005065), Washing Buffer (FB0003139), and Fluent Magnetic Cleanup Beads (FB0004980) from the Capture & Barcoding Ambient Kit and store at 2°C to 8°C.

Store the remaining components in the V T100 Capture & Barcoding Ambient Kit between 15°C to 30°C. From the V Library Prep Ambient Kit, store the Nuclease-Free Water (FB0005085) between 15°C to 30°C and the Fluent Magnetic Cleanup Beads (FB0005079) at 2°C to 8°C. Store the V T100 Capture & Barcoding -20°C Kit and the V Library Prep -20°C Kit at -25°C to -15°C.

1.2.1. PIPseq V T100 3' Capture and Barcoding Kit

Kit	Full Kit Name	Catalog Number	Storage
Ambient Kit	PIPseq V T100 3' Capture & Barcoding Ambient Kit	FB0005363	15°C to 30°C (store Washing Buffer, Breaking Buffer, and Fluent Magnetic Cleanup Beads at 2°C to 8°C upon receipt)
-20°C Kit	PIPseq V T100 3' Capture & Barcoding -20°C Kit	FB0005367	-25°C to -15°C
-80°C Kit	PIPseq V T100 3' Capture & Barcoding -80°C Kit	FB0005371	-85°C to -75°C
Consumables Kit	PIPseq V T100 3' Capture & Barcoding Consumables Kit	FB0005383	15°C to 30°C
Starter Kit	PIPseq V Universal Starter Equipment Kit	FB0005379	15°C to 30°C

1.2.2. PIPseq V Universal Starter Equipment Kit

Component Name	Part Number	Units	Used for Kit size
PIPseq Vortex Mixer	FBS-SCR-DVM	1	All
PIPseq rotating vortex assembly for 5 mL tubes	FB0003848	1	T100
PIPseq rotating vortex assembly for 1.5 mL tubes	FB0002100	1	T20
PIPseq rotating vortex assembly for 0.5 mL tubes	FB0002084	1	T2&T10
Rotating vortex base assembly	FB0003847	2	All
User manual for PIPseq Vortex Mixer	FB0002745	1	All
US Power Supplies for Vortex Mixer	FB0002353	1	All
PIPseq Combination 1.5 mL and 0.5 mL tube stand	FB0004993	2	T2,T10,T20
PIPseq 8-tube stand, black, for 0.2 mL tubes	FB0001024	1	T2
PIPseq guide rack, red	FB0001549	1	T2
International Plug Converter	FB0005397	2	All
PIPseq Dry Bath 5 mL block	FB0002675	1	T100
PIPseq Dry Bath 1.5 mL block	FB0002498	1	T20
PIPseq Dry Bath 0.5 mL block	FB0002497	1	T2&T10
US Power Supplies for PIPseq Dry Bath	FB0002363	1	All
User Manual for PIPseq Dry Bath	FB0002664	1	All
PIPseq Dry Bath with heated lid With below materials enclosed within the Dry Bath box	FBS-SCR-PDB	1	All
2.5 mm Allen key wrench, silver	FB0002666	1	
PIPseq Dry Bath Stylus	FB0002667	1	
Replacement tips for PIPseq Dry Bath Stylus	FB0002668	1	
5x20 mm 5A 250V Fast blow fuse for PIPseq Dry Bath	FB0002669	1	
Dry block removal tool, white	FB0002670	1	

1.2.3. PIPseq V T100 3' Capture & Barcoding Consumables Kit



WARNING: The materials below are necessary for the PIPseq V T100 3' Single Cell RNA workflow. The specific brands of plastic consumables have been validated for stability of PIP emulsions. Substituting these materials may adversely affect performance.

Component Name	Part Number	Units
5 mL screw-cap tubes, Eppendorf	FB0004226	1 Bag of 4

Component Name	Part Number	Units
0.2 mL PCR 8-tube strip without Cap, Greiner Bio-One, 673210	FB0002076	6 strips of 8
PCR 8-Cap strips, domed cap, Greiner Bio-One, 373270	FB0001055	6 Strips of 8
3 mL syringe	FB0002625	4
G22 blunt bottom syringe needle	FB0002623	4

1.2.4. PIPseq V T100 3' Capture & Barcoding Ambient Kit

Component Name	Storage	Part Number	Units
Partitioning Reagent	15°C to 30°C	FB0003123	2
Chemical Lysis Buffer 3 (CLB3)	15°C to 30°C	FB0005087	2
De-Partitioning Reagent	15°C to 30°C	FB0005105	1
Fluent Magnetic Cleanup Beads	2°C to 8°C	FB0004980	1
CE Buffer	15°C to 30°C	FB0005064	1
Breaking Buffer	2°C to 8°C	FB0005065	1
Washing Buffer	2°C to 8°C	FB0003139	1

1.2.5. PIPseq V T100 3' Capture & Barcoding -20°C Kit

Component Name	Storage	Part Number	Units
6X Nuclei Suspension Buffer	-25°C to -15°C	FB0005066	1
RT Enzyme Mix	-25°C to -15°C	FB0005098	1
RT Additive Mix V	-25°C to -15°C	FB0005107	2
4X PCR Master Mix	-25°C to -15°C	FB0005099	1
WTA Primer	-25°C to -15°C	FB0005091	1
RNase Inhibitor (40U/μL)	-25°C to -15°C	FB0005096	1
Cell Suspension Buffer	-25°C to -15°C	FB0005067	1

1.2.6. PIPseq V T100 3' Capture & Barcoding -80°C Kit

Component Name	Storage	Part Number	Units
T100 PIPs	-85°C to -75°C	FB0005097	2
TSO	-85°C to -75°C	FB0005110	2
25% BSA	-85°C to -75°C	FB0005088	1

1.2.7. PIPseq V Library Prep Kit

Kit	Full Kit Name	Catalog Number	Storage
Ambient Kit	PIPseq V Library Prep Ambient Kit	FB0005373	15°C to 30°C
-20°C Kit	PIPseq V Library Prep -20°C Kit	FB0005374	-25°C to -15°C

1.2.8. PIPseq V Library Prep Ambient Kit

Component Name	Storage	Part Number	Units
Fluent Magnetic Cleanup Beads	2°C to 8°C	FB0005079	1
Nuclease-free Water	15°C to 30°C	FB0005085	1

1.2.9. PIPseq V Library Prep -20°C Kit

Component Name	Storage	Part Number	Units
Library Prep Buffer	-25°C to -15°C	FB0005080	1
Library Prep Enzymes	-25°C to -15°C	FB0005081	1
Library Prep Mix A	-25°C to -15°C	FB0005082	1
Library Adapter Mix	-25°C to -15°C	FB0005083	1
4X PCR Master Mix	-25°C to -15°C	FB0005084	1
UDI Library Index Mix Strip	-25°C to -15°C	FB0005121	1

1.3. Third Party Reagent, Equipment and Consumable Requirements



WARNING: The recommendations for third party materials below have been validated in the PIPseq V 3' Single Cell RNA workflow. Substituting these materials may adversely affect performance.

1.3.1 Required Third Party Reagents

Reagent	Supplier
Cell Counting Materials using laboratory's preferred method (e.g. AO/PI)	Preferred Vendor
Nuclease-free water	Thermo Fisher; Cat # AM9937 or preferred laboratory supplier
Nuclease-free 1X low EDTA TE Buffer (IDTE), pH 8.0	IDT; Cat # 11-05-01-09 or preferred

Reagent	Supplier
10 mM Tris, 0.1 mM EDTA	laboratory supplier
Qubit 1X dsDNA High Sensitivity Assay Kit	Thermo Fisher; Cat #Q33230 or Q33231
BioAnalyzer High Sensitivity DNA kit or TapeStation HS-D5000 for cDNA and HS-D1000 for NGS library (The standard kits may be used in place of the high-sensitivity kits depending on the Qubit cDNA QC concentration)	Agilent; BioAnalyzer 5067-4626, HS-D5000 5067-5592 and 5067-5593, HS-D1000 5067-5584 and 5067-5585
100% Ethanol, molecular biology grade	General Laboratory supplier
Molecular-Biology Grade BSA Highly recommended for customers using their own nuclei isolation protocols.	Preferred Vendor

1.3.2 Required Third Party Consumables

Item	Supplier
<i>*NOTE* Sterile, low retention tips are required for this protocol. Various suppliers may be used; however only the below listed suppliers have been validated in this protocol*</i>	
Sterile Tips 20 µL, filtered, low retention	Rainin; Cat # 30389226 Filtros; Cat # PTF-LS-0020 VWR; Cat #76322-528
Sterile Tips 200 µL, filtered, low retention	Rainin; Cat # 30389240 Filtros; Cat # PTF-LS-0200 VWR; Cat # 76322-150
Sterile Tips 1000 µL, filtered, low retention	Rainin; Cat # 30389213 Filtros; Cat # PTF-LS-1000 VWR; Cat # 76322-154
Sterile Tips 200 µL, wide bore, filtered, low retention Pipette Tips RT LTS 200µL FLW 960A/10	Rainin; Cat # 30389241
Sterile Tips 1000 µL, wide bore, filtered, low retention Pipette Tips RT LTS 1000µL FLW 768A/8	Rainin; Cat # 30389218
5 mL centrifuge tubes, sterile and PCR Clean	General laboratory supplier, recommend Eppendorf # 30122321
15 mL centrifuge tubes, sterile	General laboratory supplier, recommend Corning # 430790
Qubit Assay Tubes	Thermo Fisher; Cat # Q32856
PCR strip tubes and caps, or PCR reaction plates (if you have a compatible magnetic bead rack) for workflow after cDNA amplification. <i>*NOTE*</i> Specific consumables may be required for certain steps, see warnings in protocol.	General laboratory supplier

Item	Supplier
Optional: Cell Strainers	General laboratory supplier

1.3.3. Required Third Party Equipment

Description	Supplier
3 x 15 ml / 50 ml Magnetic Separation Combo Rack	Permagen MSR1550 or MSR6X15 or equivalent from alternative supplier
Magnetic separation rack suitable for PCR tubes	General laboratory supplier
Tube rack for 5/15 mL centrifuge tubes	General laboratory supplier
Benchtop centrifuge with swinging bucket rotor, suitable for 5 mL, 15 mL tubes	General laboratory supplier, recommend ST40
Ice bucket or cold blocks, suitable for 0.2mL and 0.5mL PCR tubes and 1.5mL microcentrifuge tubes	General laboratory supplier
Hemocytometer or automated cell counter	General laboratory supplier
Micropipettes, 1µL-1000µL capabilities	General laboratory supplier
Qubit Fluorometer	Thermo Fisher
Bioanalyzer 2100 or TapeStation 4200	Agilent
Benchtop mini microcentrifuge 2000xg, suitable for 1.5 mL tubes, 0.5 mL tubes and PCR strip tubes. *NOTE* The microcentrifuge should decelerate <u>before stopping</u> in order to prevent beads from returning to the solution* The minifuge should be set to no higher than 2000xg.	General laboratory supplier e.g. USA Scientific; Cat # 2631-0006 OR Eppendorf 5420
Inserts for benchtop mini microcentrifuge that allow compatibility with 0.5 mL tubes	Provided accessory with USA Scientific 2631-0006
Thermocycler	General laboratory supplier
Swinging bucket rotor centrifuge	General laboratory supplier Eg. Thermo Scientific ST40

1.3.4. PIPseq-Compatible Alternative RNase Inhibitors

The PIPseq V T100 3' Single Cell RNA Kit contains **FB0005096 RNase Inhibitor (40U/µL)** to be added during step 6 of Capture and Lysis. Alternative RNase Inhibitors may be used during sample preparation; the following alternatives are compatible with the assay:

Description	Supplier
SUPERase RNase Inhibitor (20 U/µL)	Thermo Fisher; Cat #AM2694
Protector RNase Inhibitor (40 U/µL)	Sigma; Cat #RNAINH-RO

Description	Supplier
RiboGrip RNase Inhibitor (220 U/ μ L)	Solis Biotec; Cat #06-26-4000U
Murine RNase Inhibitor (40 U/ μ L)	Watchmaker Genomics; Cat #7K0088

1.4 Guide to Protocol Notes



Stop Point

Optional and provided for convenience.

Instructions for sample storage conditions and maximum storage time are stated at each stop point.



WARNING

Critical experimental step instructions which if performed improperly may result in compromised results.

Workflow Tip

Tips are throughout the protocol to provide the users information on how to optimize and simplify their PIPseq experience.

Troubleshooting

Guidelines on how to avoid and recover from experimental situations that need to be resolved to avoid compromised results.

OPTIONAL STEP

These steps may improve results, and can be included by the user if desired.

2. Best Practices

2.1. Working with RNA

Before executing this protocol, become familiar with working with RNA. The following section provides general guidelines for working with RNA, but the guidelines below are not all-inclusive.

- Due to the ubiquitous presence of RNases, RNA is susceptible to degradation. RNases are robust nucleases specific to RNA. Unlike DNases, they are not easily denatured or inactivated.
- **Maintain reagents, pipettes, and a work space specifically for working with RNA. An enclosed space such as a PCR hood is recommended.** Wipe down pipettes and the working space regularly with a laboratory alcohol cleaning solution (70% alcohol). Periodically (once a week to once a month), clean surfaces with a 10% sodium hypochlorite solution. Alternatively, commercial solutions are available to inactivate RNases.
- Only use consumables and reagents that are nuclease-free and dedicated for RNA use. Handle reagents carefully to avoid RNase contamination.

- The most common external RNase contamination comes from the skin. Therefore, any item that will be used for RNA work should be not handled without gloves to maintain nuclease-free surfaces. Wear a clean laboratory coat or gown to prevent shedding of skin or hair in and around the RNA work surface.
- Dust and bacteria are also sources of RNases. Keep surfaces and items free of dust and work with RNA away from bacterial processes.
- Refrigerator and freezer handles should be treated as RNase-free surfaces and should only be opened with gloved hands.
- Exercise all standard laboratory best practices such as always wearing PPE, not touching rims of open tubes, and not reusing pipette tips. Seal consumable bags and reagent tubes tightly when not in use.

2.2. Working with PCR Products

Before executing this protocol, become familiar with the process of unidirectional PCR workflow and managing PCR amplicon products. **All steps in the PIPseq workflow should be completed in a pre-PCR workspace until after the thermocycling step during Sample Index PCR.** All remaining steps should be completed in the post-PCR workspace. One exception is the magnetic bead purification following the cDNA QC amplification, which should also be completed in the post-PCR workspace. The following section provides general guidelines for working with PCR products, but the guidelines below are not all-inclusive.

- PCR by design creates a large number of amplicons, copies of the input material. This strength of PCR also comes with the risk of amplicon contamination of workspaces and materials.
- It is best practice to maintain two separate workspaces for pre and post PCR work. Ideally these spaces would be physically divided and each would have a dedicated set of equipment and materials. All work before a PCR amplification would be performed in the pre-PCR workspace and the sample would then be transferred to the post-PCR workspace for further processing. No material from the post-PCR workspace would ever come back into the pre-PCR workspace.
- For some reagents and consumables, multiple sets may be required for pre-PCR and post-PCR workspace use to avoid carryover contamination.
- If it is not possible to maintain two separate workspaces for pre and post PCR work, it is still highly recommended to **keep two separate sets of consumable materials** and to maintain strict workplace sterility. Make sure all benches and equipment are regularly cleaned with a bleach solution or a commercial DNA degrader to reduce contaminating amplicons and always wear clean gloves.

2.3. Centrifuge Steps

All centrifuge steps in the PIPseq V workflow after sample preparation where the sample is in 1.5 mL or PCR tubes should be completed with a benchtop minifuge using speeds of 2000 x g or less. For steps where the sample is in a 5 mL or 15 mL conical, a swinging bucket rotor centrifuge must be used.

2.4. Thermocycler Lid Pressure

Be sure to follow the manufacturer's instructions for using PCR strip tubes with your brand of thermocycler. Thermocyclers with a lot of lid pressure can cause the 8-tube strip to collapse during Whole Transcriptome Amplification or Sample Index PCR when only one is used. It is recommended to use empty strip tubes as braces surrounding both sides of the 8-tube strip to help balance the lid pressure for brands that do not include plastic frame supports.

2.5. Cell Loading

This protocol describes addition of 200,000 cells into each PIPseq reaction, resulting in recovery of > 100,000 cells and a multiplet rate of < 8%*. The optimal input cell concentration is 10,000 live cells per microliter when adding 20 µL of cells plus 160 Units of RNase inhibitor into each PIP tube (refer to section 5.1.5). If it is not possible to concentrate cells to 10,000 cells/µL, a lower concentration may be used (up to 200,000 live cells total) if the total loading volume including RNase inhibitor is ≤30 µL. It is important to note that increased cell input will increase the observed multiplet rate.

3. PIPseq Equipment Preparation

3.1. PIPseq Vortexer Operation

The PIPseq Vortexer and accessories provided in the Starter Equipment Kit are critical for the carefully controlled vortexing that produces high-quality Particle-templated Instant Partitions (PIPs).



WARNING: Make sure that the 5 mL tube vortexer head is installed on the PIPseq Vortexer before starting the protocol.

The vortex adapter head (yellow) is attached to the vortex base (gray) with a thumbscrew. The thumbscrew should be fastened from the front of the vortex mixer (see below). For further information on proper installation, review FB0003717 PIPseq Vortex Adapter Installation Guide.

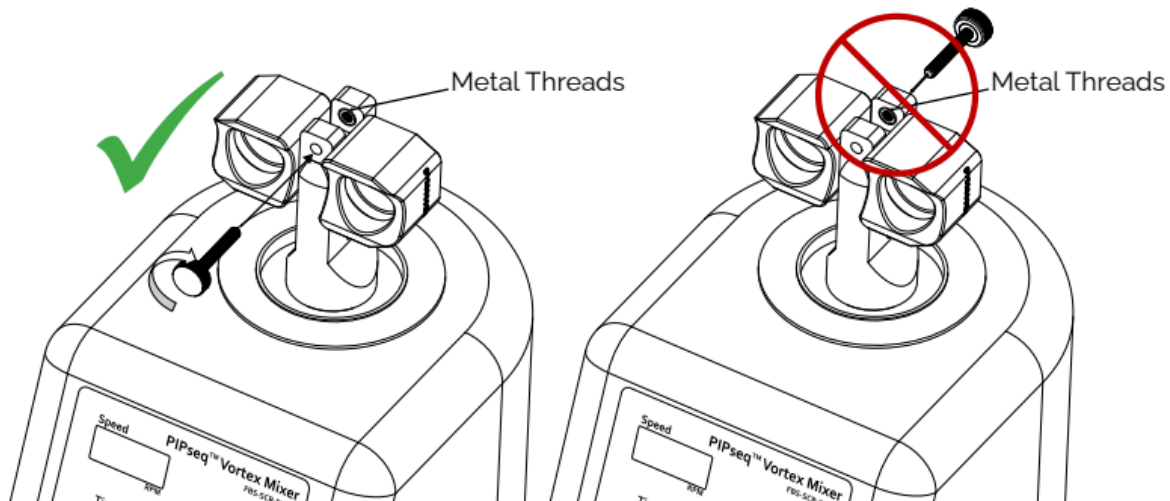

The thumbscrew should be just tight enough so the adapter does not rotate during vortexing, but not tight enough to make rotating from horizontal to vertical orientation difficult. The tightness of the thumbscrew may need to be periodically adjusted.

Users will be required to change the rotating vortex adapter from horizontal to vertical position during the PIPseq protocol. It is recommended that users **practice this rotation** before starting the protocol so the process can be completed in under 30 seconds.

3.2. PIPseq Dry Bath Operation

3.2.1. PIPseq Dry Bath

The PIPseq Dry Bath (Figure 1) and accessories enable precise, programmable thermal incubation of samples in 0.5 mL - 5 mL tubes, essential for sample scalability beyond volumes a standard thermocycler is capable of. The PIPseq Dry Bath is pre-programmed with the necessary incubation protocols. It is important to familiarize yourself with the protocol usages and PIPseq Dry Bath operation before use.



WARNING: Make sure the 5 mL tube block is installed in the PIPseq Dry Bath before starting the protocol.

3.2.2. PIPseq Dry Bath Lid Settings and Control

The PIPseq Dry Bath lid temperature will need to be manually turned off, as it is not necessary for the PIPseq V T100 scale reactions. Please note the lid heating mode is independent of the set programs. This mode applies across all programs, regardless of thermal profiles settings. The indicator light will flash when the PIPseq Dry Bath is preheating, and turn solid when the designated temperature has been reached.

3.2.3. PIPseq Dry Bath Control

Changing the lid temperature and lid heating mode:

1. Determine if the lid temperature control is on or off by checking the button on the bottom-right corner of the screen. The button will display “LidOff” if the lid is ON or “LidOn” if the lid is OFF.
2. If the lid button is set to “LidOff”, press the button to turn **OFF** the lid heating feature.

Dry Bath interface:

1. Both “preheat” and “hold” are depicted as “00:00.”
2. In order to begin the program from the “preheat” setting, you must press “skip to next step.”

3.2.4. PIPseq Dry Bath Protocols

Program	A	B	C
Application	Cell Lysis	Nuclei Lysis	Reverse Transcription
Lid Setting	OFF	OFF	OFF
Step 1	25°C - preheat	66°C - preheat	25°C - preheat
press	“Skip” then confirm skip by pressing “yes” to proceed to next step		
Step 2	25°C - 15 min	66°C - 45 min	25°C - 30 min
Step 3	37°C - 45 min	25°C - 10 min	42°C - 90 min
Step 4	25°C - 10 min	20°C - hold	85°C - 10 min
Step 5	20°C - hold		4°C - hold



Figure 1. Dry Bath interface programmed for cell lysis protocol. Both “preheat” and “hold” functions are depicted as “00:00” on the Dry Bath interface. In order to start pre-heating, one must first press “run”. When samples are inserted, press the “Skip” and then “yes” to continue the protocol.

4. Sample Preparation

The PIPseq single cell protocol requires a suspension of high-quality single cells or nuclei as input which may be derived from cell cultures, dissociated tissues, cell sorting, or other isolation methods. Users should minimize the presence of dead cells or aggregates to ensure the highest quality data. Minimize the amount of time it takes for sample preparation through Capture and Lysis, and add RNase inhibitor at 0.4-1 U/ μ L final concentration to buffers being used in lengthy steps (e.g., dissociation, enrichment, sorting collection tubes, or sample suspension buffers). Use higher RNase inhibitor concentrations for challenging sample types. When processing many samples together at once, it is recommended to process sample preparations in batches through Capture and Lysis to prevent mRNA degradation. See section 4.1 for cell or 4.2 for nuclei sample preparation instructions.

It is recommended to complete Reagent and Material Preparation for Capture and Lysis (section 5.1) prior to starting sample preparation. The PIP tubes can be thawed and stored on ice for up to 5 hours. It is best practice to start Capture and Lysis as soon as possible after diluting samples to the target concentration.

4.1. Cell Preparation

This section describes a generic protocol for thawing, washing, and resuspending **mammalian fresh or cryopreserved cell lines**; however, this protocol may not be generalizable to all cell types. Preparation of single cell suspensions from tissues or fragile cell types may require additional dissociation or cell handling steps which are not described here. For single nuclei preparation, refer to section 4.2.

Users may substitute their own cell preparation protocol; however, **the final cell dilution step must be performed with the Fluent Cell Suspension Buffer**. Usage of wide-bore pipette tips is recommended to minimize cell damage.

Reagent and Material Preparation			
Component Name	Part Number	Kit	Preparation
Cell Suspension Buffer	FB0005067	-20°C Kit	Warm to 37 °C in a water bath
Cryopreserved cells	Customer provided	N/A	Keep frozen until use
Thawing media	Customer provided, specific to cell type of choice	N/A	Warm to 37 °C in a water bath
Wide-bore P1000 pipette tips	Customer provided	N/A	Obtain
Flo-Mi 40 μ M pipette tip strainers	Optional, customer provided	N/A	Obtain
Cell counting materials	Customer provided	N/A	Obtain

1. Obtain cryopreserved cell vial from liquid nitrogen storage. **If starting from fresh cells and/or substituting your own cell preparation protocol, skip to step 6. With fresh cells, cold Cell Suspension Buffer can be substituted for pre-warmed.**
2. Place the cryopreserved cell vial and an aliquot of Cell Suspension Buffer in a water bath set to 37 °C.
3. After **1-1.5 minutes** of thawing, when only a small ice chunk remains (60-70% thawed), remove the vial from the water bath, decontaminate the outside with 70% isopropyl alcohol, and move it into the biosafety cabinet.

Workflow Tip: *The remaining ice will thaw over the next 30-60 seconds at room temperature.*

4. Use a **wide-bore** P1000 or 2 mL serological pipette to gently mix and transfer the cell suspension to a 15 mL conical tube. Make sure to collect all cell contents from the vial.
5. **Slowly** add 9 mL of warmed thawing media to the cell suspension in the 15 mL conical tube and mix by inversion three to five times.

Workflow Tip: *The initial 2 mL of warmed thawing media should be added to the cell suspension slowly over **at least** 30 seconds.*

6. Centrifuge cells at 200 x g for 5 min at room temperature to pellet.



WARNING: Swinging bucket rotors are highly recommended for pelleting to minimize cell shearing and sample loss.

Centrifugation speed and time is cell type specific, optimization may be necessary to find the minimum speed and time required for pelleting. Generally, up to 350 g x 5 min can be used for smaller cell types.

7. Aspirate as much of the supernatant as possible without disturbing the cell pellet.



WARNING: The wash step is required to remove reagents inhibitory to PIPseq from the cell suspension (e.g., FBS, BSA >1%, high salts, calcium, etc.) If unable to leave less than 100 µL supernatant remaining, the wash volume should be increased to 2 mL pre-warmed Cell Suspension Buffer.

8. Add 1 mL pre-warmed Cell Suspension Buffer and gently mix to resuspend the pellet 5 times with a **wide-bore** P1000 pipette tip. **Place the remaining Cell Suspension Buffer on ice to cool.**
9. Centrifuge cells at 200 x g for 3 min at room temperature to pellet.
10. Aspirate as much of the supernatant as possible without disturbing the cell pellet.
11. Using a **standard** bore pipette tip, add 200-400 µL of **cold** Cell Suspension Buffer and gently mix 10-15 times until the cells are completely resuspended.

Workflow Tip: *If clumps are visible, increase the amount of force used during pipet mixing. Use the minimum force necessary to create a homogeneous cell suspension.*

Optional Step: Passing the cell suspension through a cell strainer will help remove debris and dead cells, and is highly recommended for cell types prone to forming aggregates. Please note that up to 30% of cells may be lost during filtration and this process adds further stress to the cells. Users may choose to skip filtration if their cell type is not prone to clumping, since instrument clogging is not an issue with PIPseq.

- Using a **wide-bore** pipette tip and withdraw 200 μL of the cell suspension.
- Gently dispense the cell suspension through the cell strainer into a fresh 1.5 mL tube.
- Repeat until all cell suspension has been passed through the cell strainer.

Workflow Tip: Do not “blow out” while pushing the cell suspension through the strainer as this will push unwanted debris through.

12. Determine cell concentration using the laboratory’s preferred method (e.g. trypan blue or AO/PI staining on an automated cell counter).



WARNING: Cells should have >90% viability to proceed. Perform filtration as described in the optional steps above or an additional wash step to remove debris and improve viability if necessary. Always perform a final count.

13. Using a **wide-bore** low retention pipette tip, prepare 10,000 live cells/ μL suspension in Cell Suspension Buffer to achieve an input volume of 20 μL (200,000 live cells) into a PIP reaction (refer to step 5.1.5). If it is not possible to concentrate cells to 10,000 cells/ μL , a lower concentration may be used (up to 200,000 live cells total) if the total loading volume including RNase inhibitor is kept $\leq 30 \mu\text{L}$.
14. Repeat the cell count described in step 12 to confirm the final concentration in the prepared suspension. Adjust concentration and repeat count as necessary.
15. Once the required concentration is achieved, place the cells on ice and **proceed directly** to section 5: PIPseq V T100 protocol.

4.1.2 Working with Fixed Cells

Fixed cells generated according to FB0004708 DSP-Methanol Fixation for Cells are compatible with PIPseq. If cells are in media containing FBS or BSA, complete a 1 mL wash step using Cell Suspension Buffer, then resuspend in Cell Suspension Buffer that does not include additional BSA or RNase inhibitor prior to starting the fixation protocol. This fixative yields comparable performance as fresh cells. Fixed cells may be stored for up to 7 days at -20°C . Please note alternative fixation approaches (e.g. formaldehyde) have not yet been validated in PIPseq and are not recommended.

4.2. Nuclei Preparation

4.2.1. Nuclei Isolation

Fluent recommends that users prepare nuclei suspensions using the **Fluent V Nuclei Isolation Kit** (FB0005375) to ensure consistent, high-quality nuclei across a diversity of tissues. See FB0003716 Fluent V Nuclei Isolation Kit User Guide for instructions. If using an alternative nuclei isolation protocol, users **must use the provided FB0005066 6X Nuclei Suspension Buffer (NSB) to prepare complete 1X NSB (see section 4.2.3) for the final nuclei suspension.** Users are **strongly advised** to substitute 1X NSB for the wash steps in the alternative nuclei isolation protocol (at least 1 mL of 1X NSB in up to two wash steps) as described in further detail below. This kit only includes enough BSA for the final nuclei suspension, so customers using alternative nuclei isolation protocols will need to add their own BSA (1% final concentration) and RNase inhibitor (0.8U/ μ L final concentration) if they want these included for the wash steps.



WARNING: The wash step is required to remove reagents inhibitory to PIPseq from the nuclei suspension (e.g., FBS, BSA >1%) If unable to leave less than 100 μ L supernatant remaining, the wash volume should be increased to 2 mL.

Alternative nuclei isolation protocols:

- When using alternative nuclei isolation protocols it is necessary to include 0.8 U/ μ L RNase inhibitor final concentration and 1X protease inhibitor into the nuclei extraction buffer/nuclei lysis buffer during tissue lysis.
- Once nuclei extraction is done, centrifuge nuclei suspension (preferably, 500 x g for 5 minutes at 4°C) to pellet and aspirate supernatant. Use a P200 to carefully remove as much supernatant as possible without disturbing the pellet.
Workflow Tip: Using a fixed angle centrifuge for pelleting nuclei for wash steps can result in excessive sample loss. Tubes compatible with swinging bucket rotor centrifuges should be used to ensure a flat pellet.
- Add 1 mL of 1X NSB, mix well and spin at 500 x g for 5 minutes at 4°C.
- Next, aspirate supernatant without disturbing the pellet and resuspend nuclei using 1X NSB.

Best practices for all nuclei isolation protocols: Count with a fluorescent nucleic acid stain (e.g. AO/PI) using size gating and assess morphology of nuclei using a fluorescent-capable automated counter, then dilute in 1X NSB to the target concentration of 10,000 nuclei/ μ L for a 200,000 nuclei input when adding 20 μ L of nuclei plus 40 Units of RNase inhibitor into each PIP tube, refer to step 5.1.5. If it is not possible to concentrate nuclei to 10,000 nuclei/ μ L, a lower concentration may be used (up to 200,000 nuclei total) if the total loading volume including RNase inhibitor is kept \leq 30 μ L.

Place samples on ice and proceed immediately to Capture and Lysis. Do not freeze isolated nuclei. If not proceeding directly to Capture and Lysis, it is recommended to fix nuclei to prevent mRNA degradation. Refer to Section 4.2.2 for further details.

See section 4.2.3 below for instruction on preparing Nuclei Suspension Buffer for various applications. See FB0003716 PIPseq Nuclei Isolation Kit User Guide for recommendations on the resuspension volume per mg tissue for various tissue types. Please note it is not recommended to process more than 50 mg of tissue per sample at once in order to achieve optimal lysis.

4.2.2. Working with Fixed Nuclei



WARNING: It is critical to use Nuclei Suspension Buffer without BSA and RNase inhibitor for resuspending nuclei prior to fixation.

Fixed nuclei are compatible with PIPseq. Prior to starting the fixation protocol nuclei must be resuspended in Nuclei Suspension Buffer **without** BSA or RNase inhibitor. Please refer to FB0004745 for instructions on fixing isolated nuclei. Users are **strongly advised** to substitute 1X NSB for the wash steps in the alternative nuclei fixation protocol (at least 1 mL of 1X NSB without BSA or RNase inhibitor in up to two wash steps and the final resuspension prior to fixation). Fixed nuclei may be stored for up to 2 months at -20°C.

4.2.3. Nuclei Suspension Buffer Preparation

Nuclei Suspension Buffer for Fresh Nuclei: Combine 167 uL of kit provided 6X Nuclei Suspension Buffer (FB0005066), 40 uL of kit provided BSA (FB0005088), 773 ul of customer provided nuclease-free water, and 20 uL of RNase inhibitor (40 U/μL) (FB0005096) (or 40 μL of RNase inhibitor if provided at 20 U/μL and 753 μL of nuclease-free water, refer to RNase inhibitor recommendations in section 1.3.4) to prepare 1 mL of complete 1X Nuclei Suspension Buffer. Prepare sufficient volume for at least 2 x 1 mL washes and the final suspension with complete 1X Nuclei Suspension Buffer per sample. Note that exact volumes required may be sample size and type specific to achieve optimal nuclei concentration.

Nuclei Suspension Buffer for Fixed Nuclei: Combine 167 uL of kit provided 6X Nuclei Suspension Buffer (FB0005066) and 833 uL of customer provided nuclease-free water to prepare 1 mL of BSA/RNase Inhibitor-Free 1X Nuclei Suspension Buffer. Prepare sufficient volume for at least 2 x 1 mL washes and the final suspension (refer to FB0004745 for the volume to use for the final suspension prior to fixation) with BSA/RNase Inhibitor-Free 1X Nuclei Suspension Buffer per nuclei sample. Note that exact volumes required may be sample size and type specific to achieve optimal nuclei concentration.

Component Name	Part Number	Fresh Nuclei	Fixed Nuclei
		1X NSB Volume (μL)	1X NSB Volume (μL)
6X Nuclei Suspension Buffer	FB0005066	167	167
Nuclease-Free Water	Customer Provided	773	833
BSA (25%)	FB0005088	40	N/A
RNase Inhibitor (40 U/μL)	FB0005096	20	N/A
Total		1000	1000

5. PIPseq V T100 Protocol

5.1. Capture and Lysis

Reagent and Material Preparation			
Component Name	Part Number	Kit	Preparation
T100 PIPs	FB0005097	-80°C Kit	Thaw one tube per sample on ice (~15-30 minutes), centrifuge for ~5 seconds.
RNase Inhibitor	FB0005096	-20°C Kit	Thaw on ice
Partitioning Reagent	FB0003123	Ambient Kit	Obtain, keep at room temperature
Chemical Lysis Buffer 3 (CLB3)	FB0005087	Ambient Kit	Obtain, keep at room temperature
PIPseq Dry Bath with heated lid	FBS-SCR-PDB	Starter Kit	Preheat with appropriate Cell or Nuclei Lysis program (refer to section 3.2.4)
PIPseq Dry Bath 5 mL block	FBS-SCR-PDB	Starter Kit	Ensure the 5 mL block is installed in PIPseq Dry Bath
PIPseq Vortex Mixer	FBS-SCR-DVM	Starter Kit	Place head in horizontal position (Figure 2A)
Wide-bore P200 pipette tips	Customer provided	N/A	Obtain
3 mL syringe	FB0002625	Consumables Kit	Obtain
G22 blunt bottom syringe needle	FB0002623	Consumables Kit	Obtain
5 mL screw cap Eppendorf tube, gray cap	FB0004226	Consumables Kit	Obtain, one tube per sample

1. Prepare a single cell or nuclei suspension at your targeted concentration (refer to Section 4.1.1.13) **in the provided Cell Suspension Buffer or appropriately prepared Nuclei Suspension Buffer (refer to Section 4.2.3).**
2. Thaw one PIP tube for each sample to be processed on ice. Once fully thawed, centrifuge PIP tubes for ~5 sec on a swinging bucket centrifuge at 750 x g and place them on ice.

Workflow Tip: It is highly recommended to process at least 2 samples at once, to balance centrifuge steps. If only processing 1 sample, it is required to use the same tube type as

those used for the PIPs (Eppendorf Cat# 30122321, not provided in kit), carefully balanced with water.

3. Preheat the PIPseq Dry bath and lid with the **5 mL tube block** to hold at the appropriate temperature depending on sample input type (cells or nuclei). Refer to section 3.2 *PIPseq Dry Bath Operation* for sample type specific programs.
4. Gently mix the cell or nuclei suspension 10 times with a **wide-bore** P200 tip.
5. Add 20 μL cell or nuclei suspension at 10,000 cells/ μL (200,000 total) directly into the PIPs. If it is not possible to concentrate cells or nuclei to 10,000 cells/ μL , a lower concentration may be used (up to 200,000 live cells or nuclei total) if the total loading volume including RNase inhibitor (see Step 6) is kept $\leq 30 \mu\text{L}$.
6. Add 160 units of RNase inhibitor directly into the PIPs. Dispense slowly to avoid forming bubbles.

Workflow Tip: Ensure cells are dispensed into the PIPs layer and not just on the surface of the PIPs. If performing multiple reactions, add cells to all PIP tubes before proceeding to the next step.



WARNING: It is required to add 160 units of RNase Inhibitor. If preferred, alternative brands of RNase Inhibitors may be used, see section 1.3.4 for recommendations.

7. Mix the cell:PIP mixture 10 times using a **standard bore**, low-retention P1000 tip at 650 μL stroke to ensure even dispersal of sample in PIPs.



Troubleshooting: Avoid creating foam, mix the viscous cell:PIP mixture slowly and do not blow out the pipette tip. If excessive foam forms, centrifuge the PIP tubes on a minifuge for ~ 5 seconds and repeat the mixing in step 5.

8. Add 4000 μL Partitioning Reagent down the side wall of the PIP tube using a P1000 pipette. Do not use serological pipettes.
9. Tightly cap tubes and place **one tube** in the rotating vortex adapter in the horizontal configuration (Figure 2A). Ensure the tube is fully inserted into the adapter and **vortex at 3000 RPM for 20 seconds.**

WARNING: When processing two T100 reactions at the same time, it is recommended to vortex one tube in both the horizontal and vertical configuration, followed by the second tube. It is not recommended to vortex both tubes at the same time unless the PIPseq vortexer is stabilized by placing a rubber mat underneath.

10. Rotate the vortex adapter into the vertical configuration (Figure 2B) and **vortex vertically at 3000 RPM for 2 minutes.**

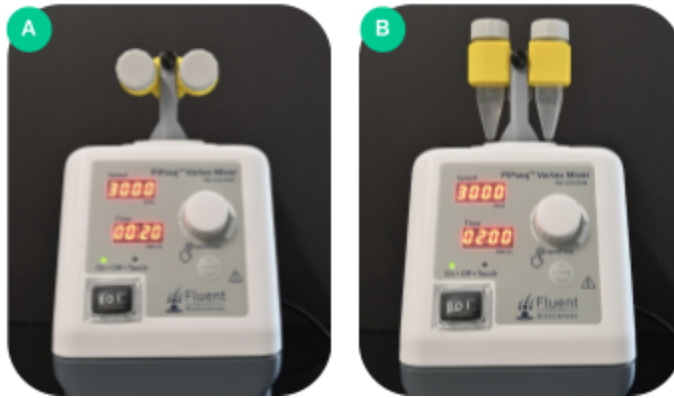

Figure 2. (A) Vortex adapter in horizontal position (B) Vortex adapter in vertical position.

11. Remove the PIP tubes from the vortexer and place in a 5 or 15 mL centrifuge tube rack. **Let the emulsion stabilize for at least 1 minute** before proceeding.

***Workflow Tip:** The cloudy reaction will separate into two phases, PIPs+cells emulsion on top and Partitioning Reagent on the bottom. (Figure 3).*

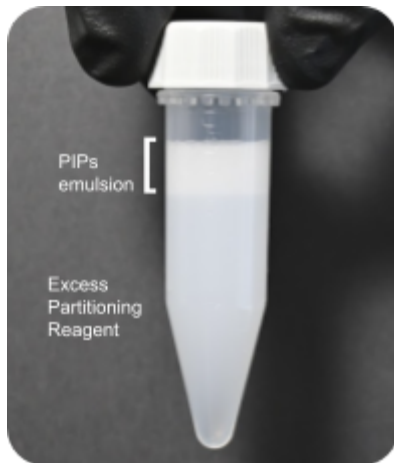

Figure 3. Emulsified PIPs and cells are seen in the top phase while the excess waste Partitioning Reagent is in the bottom phase.

12. Remove and discard the Partitioning Reagent waste (**bottom phase**) from each PIP tube using a G22 blunt tip syringe needle on a 3 mL syringe (Figure 4A) until the bottom of the PIPs + cells emulsion reaches the **1 mL volume marker** on the 5 mL tube (Figure 4B). **Be careful not to aspirate any emulsion.**

***Workflow Tip:** Draw a line at 1mL marker to visualize more easily. Use following best practices for pipetting through an emulsion. Slowly lower the tip through the emulsion to the bottom of the tube, wait for five seconds, and then aspirate the bottom phase (Figure 4A). As you remove the tip, wipe on the side of the tube to ensure no sample is lost prior to discarding the excess Partitioning Reagent.*

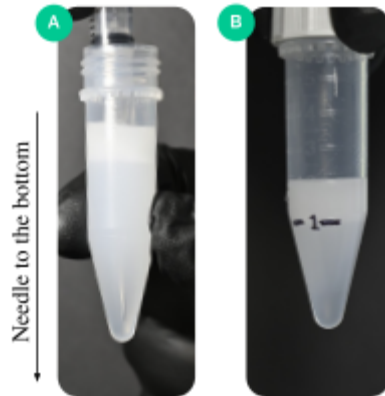

Figure 4. Use a 3 mL syringe with a G22 blunt bottom needle to remove excess Partitioning Reagent (A) from the bottom phase. Remove excess until the bottom of the PIPs layer sits at or below the 1 mL mark on the tube as shown in (B).

Troubleshooting: Prior to use, visually inspect CLB3 tubes for any indication of crystallization (the presence of a translucent, crystal lattice structure). If crystals are apparent, equilibrate the tubes to room temperature using the provided Dry Bath set to 25°C, vortex the tubes for 10 seconds, and briefly centrifuge.

13. Prepare one Chemical Lysis Emulsion tube **per reaction**. Label one of the provided 5 mL Screw-Cap tubes from the Consumables kit per sample being processed as “CLB3”. Aliquot 840 uL of Chemical Lysis Buffer 3 (CLB3) (FB0005087) into each of the labeled CLB3 tubes. Then add 2500 µL of Partitioning Reagent to each 5 mL tube containing CLB3 to prepare the Chemical Lysis Emulsion.



WARNING: Do not prepare chemical lysis emulsion in bulk; CLB3 must be aliquoted into individual 5 mL tubes and Partitioning Reagent must be individually added to each aliquot.

14. Vortex the Chemical Lysis Emulsion for 10 seconds and **immediately** pour the whole volume of one Chemical Lysis Emulsion (~3300 µL) to each of the PIP tubes.
Workflow Tip: Use one full tube of Chemical Lysis Emulsion for each PIP tube. Vortexing thoroughly before addition is important to form the emulsion.
15. Mix the cloudy combined emulsions gently by inversion at least 10 times.
16. Verify the PIPseq Dry Bath is preheated to the appropriate temperature for the sample type (see diagrams below). **Ensure the heated lid is off by pressing “LidOff”.**
Workflow Tip: When the heated lid is off there will **not** be a green dot next to the lid temperature.

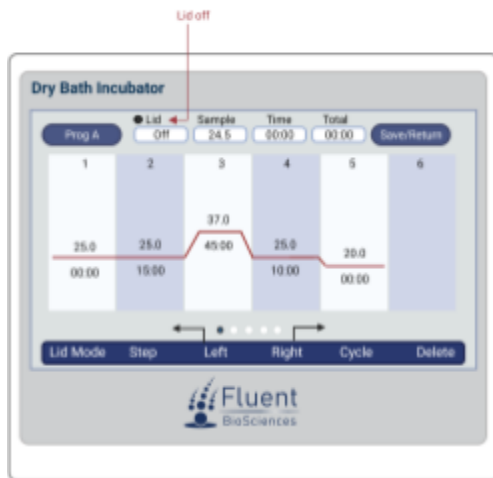

Cell Lysis Program

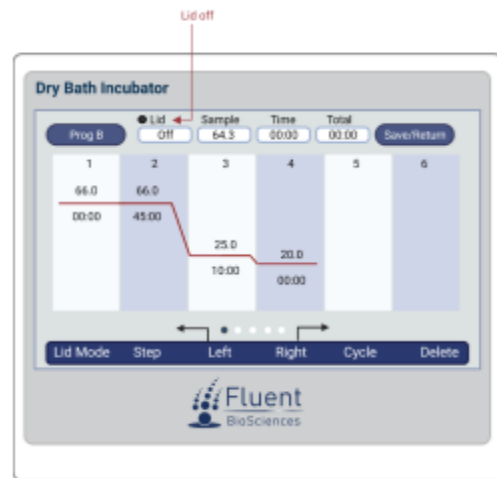

Nuclei Lysis Program

17. Insert the samples into PIPseq Dry Bath and select **skip** and **yes** to begin the lysis incubation.



18. **Stop Point:** Once incubation is complete samples can be held at 20°C for up to 96 hours. Alternatively, you can proceed immediately to mRNA isolation.

Workflow Tip: If continuing to mRNA isolation step, complete 5.2.1 Reagent Preparation during the incubation.



WARNING: Do not refrigerate or freeze samples.

Troubleshooting: Some condensation may appear on the tubes, which is not a concern.

DO NOT centrifuge the emulsion. If liquid remains on the tube cap, invert the sample 3 times.

5.2. mRNA Isolation

Reagent and Material Preparation			
Component Name	Part Number	Kit	Preparation
Breaking Buffer	FB0005065	Ambient Kit (stored at 2°C to 8°C)	Warm to room temperature (at least 20 minutes before use)
Washing Buffer	FB0003139	Ambient Kit (stored at 2°C to 8°C)	Keep chilled on ice at all times. Prepare 1X Washing Buffer aliquots.
De-Partitioning Reagent	FB0005105	Ambient Kit	Obtain, keep room temperature
RT Additive Mix V	FB0005107	-20°C Kit	Thaw on ice, pipette mix prior to use
TSO	FB0005110	-80°C Kit	Thaw one tube per sample on ice
G22 blunt bottom syringe needle	FB0002623	Consumables Kit	Obtain and attach to syringe, one per sample
3 mL syringe	FB0002625	Consumables Kit	Obtain and attach to needle, one per sample
5 mL screw cap Eppendorf tube, gray cap	FB0004226	Consumables Kit	Obtain
15 mL centrifuge tubes, sterile	Customer provided	N/A	Obtain

5.2.1. Reagent Preparation

1. Warm **Breaking Buffer** to room temperature for at least 20 minutes.
2. Make one 10 mL aliquot of **1X Washing Buffer** per sample in a 15 mL centrifuge tube. Label as Wash 1 and store on ice until use. Place the stock bottle of 1X Washing Buffer back at 4°C or store on ice.
3. Thaw one tube of **TSO** per sample on ice.



WARNING: For best results, do not attempt to rapidly thaw TSO at ambient temperature or by hand.

5.2.2. Breaking Emulsions



WARNING: Do not centrifuge the emulsion.

1. Remove PIP tubes from the Dry Bath and place into a 5 or 15 mL centrifuge tube stand.
2. Remove and discard the remaining Partitioning Reagent using a G22 blunt bottom syringe needle on a 3 mL syringe until the top of the emulsion is below the **1.5 mL marker of the tube** (Figure 5).

Workflow Tip: Save the syringe and needle from this step for step 8. Label the syringe with the sample name if processing multiple samples.

WARNING: Do not discard any of the PIP layer! Use the following best practices when pipetting through an emulsion. Slowly lower the tip through the emulsion to the bottom of the tube, wait for five seconds, and then aspirate out the bottom phase (Figure 5A). While aspirating, keep the syringe at the bottom of the tube to avoid aspiration of any PIPs! As you remove the tip, wipe it on the inside of the tube to ensure no sample is lost. Move slowly to avoid mixing the PIPs into the Partitioning Reagent layer. **Remove as much of the bottom layer (Partitioning Reagent and CLB3 emulsion) as possible, ensuring the top of the emulsion phase is visibly below the 1.5 mL marker on the tube.** The volume of the PIP emulsion is < 1 mL.



Figure 5. PIP tubes after removing them from the Dry Bath (A) and after discarding the remaining excess Partitioning Reagent and CLB3 emulsion (B).

3. Add **2500 μ L of Breaking Buffer** (clear) to each sample, along the side wall of the tube.
4. Add **800 μ L of De-Partitioning Reagent** (pink) to each sample, along the side wall of the tube (Figure 6A).
5. Securely close the tube, then fully invert the tube 10-20 times to break the emulsion. (Figure 6B).



WARNING: DO NOT vortex the tube during breaking.

7. Centrifuge for 1 minute on a swinging bucket centrifuge at 750 x g.



WARNING: Ensure the emulsion is completely broken by visually confirming a distinct interface between the pink bottom phase (Figure 6A, lower) and the upper homogeneous aqueous layer containing the PIPs (Figure 6A, upper).

Workflow Tip: Confirm whether there is any inhomogeneity in the opaque upper phase which is a sign of unbroken PIPs (see Appendix IV for further information). **If unbroken PIPs are observed, add 80 μ L additional De-Partitioning Reagent and repeat Steps 5 and 6 to ensure all PIPs are broken. If unbroken PIPs still remain, users can add 400 μ L additional De-Partitioning Reagent and repeat Steps 5 and 6.**

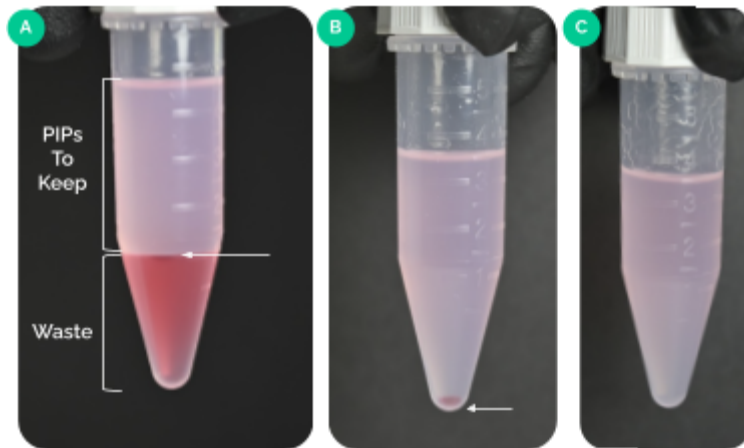

Figure 6. The PIPs are now suspended in the opaque top phase (A) after inverting and spinning down as described in Steps 5-6. Take note of the red droplet of waste that must be completely removed (white arrow). After removal of the pink waste phase with the syringe and needle, the PIPs phase should look like (B) after spinning down again for Step 8. After final removal in step 9, PIP phase should look like (C).

8. **Remove ALL of the pink-colored bottom phase** from each tube of PIPs using the G22 blunt bottom syringe needle on a 3 mL syringe (save the syringe for use in step 10).
9. Centrifuge for 1 min on a swinging bucket centrifuge at 750 x g.
10. Remove **ALL** remaining pink-colored bottom phase with the G22 blunt bottom syringe needle on a 3 mL syringe.

Workflow Tip: If a red droplet is observed, remove the bottom pink waste phase first and bring the red droplet to the bottom of the tube. Move the syringe tip in a very slow circular motion at the bottom of the tube to ensure complete removal of the pink waste phase and the red droplet (Figure 6B).



WARNING: It is critical to ensure all of the pink bottom phase is removed. It is acceptable to remove a small amount of the clear aqueous to ensure complete removal. If there are unbroken PIPs or pink waste remaining, it can inhibit reverse transcription and cause lower cDNA yield and fragment sizes.

11. Place the tubes on ice and then proceed **immediately** to the next step.



WARNING: Do not allow the PIP tubes to freeze. This will negatively impact assay performance.

5.2.3. Washing PIPs with 1X Washing Buffer

1. Using a P1000 low retention tip, slowly transfer the PIPs into the chilled Wash 1 aliquots prepared earlier.
2. Briefly centrifuge the 5 mL tube on a swinging bucket centrifuge after the first transfer to collect all remaining PIPs. Transfer remaining PIPs from the 5 mL tube into the respective 15 mL tube containing the previously transferred PIPs (Wash 1).



WARNING: Make sure all PIPs have been transferred to the 15 mL tube, with none left in the 5 mL tube or pipette tip. Wash the pipette tip inside the 15 mL wash tube by mixing up and down at least three times.

3. Gently mix each tube by tapping the bottom to disperse the pellet and invert 10 times.
4. Centrifuge the tubes for 2 minutes at 750 x g (use ~70-80% of the maximum braking speed) on a centrifuge with a swinging bucket rotor (e.g. ST40) to pack the PIPs (Figure 7).

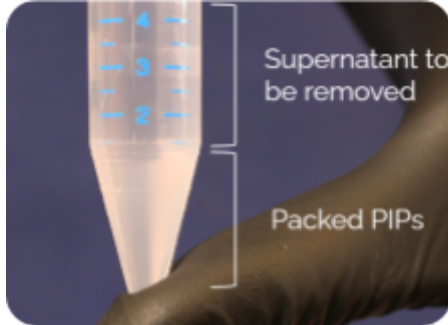

Figure 7. Packed PIPs after centrifuging.

5. Remove supernatant until 2 mL Washing Buffer remains. DO NOT disturb the PIPs pellet.

Workflow Tip: For all supernatant removal steps it is convenient to use an aspirator. Ensure a clean tip is used for each aspiration.

Wash Checklist	
Wash 1	<input type="checkbox"/>
Wash 2	<input type="checkbox"/>
Wash 3	<input type="checkbox"/>
Wash 4	<input type="checkbox"/>



WARNING: Do not aspirate below 1 mL to avoid loss of PIPs. Aspirate slowly and carefully while keeping the tip at the top of the liquid level; don't disturb the pellet.

6. Add 12 mL of 1X Washing Buffer from the stock bottle directly into the Wash 1 tubes containing packed PIPs and **repeat steps 3-6 two times for Wash 2 and Wash 3, then repeat steps 3 - 5 for Wash 4 (for a total of 4 washes).**
7. Transfer the PIPs mixture (~ 1.5-2 mL) into the clean 5 mL tube (provided with T100 kit) using a P1000 low retention tip.
8. Centrifuge the 5 mL tube in a swinging bucket centrifuge for 2 minutes at 750 x g with 70-80% of maximum braking force.
9. Use a P1000 to remove the remaining supernatant to the 1 mL volume marker on the tube.
10. Place tubes on ice and proceed directly to cDNA synthesis.



WARNING: Do not disrupt packed PIPs.

5.3. cDNA Synthesis

Reagent and Material Preparation			
Component Name	Part Number	Kit	Preparation
RT Enzyme Mix	FB0005098	-20°C Kit	Thaw on ice; pipette mix prior to use
RT Additive Mix V	FB0005107	-20°C Kit	If not prepared earlier, thaw on ice, pipette mix prior to use
TSO	FB0005110	-80°C Kit	If not prepared earlier, thaw one tube per sample on ice
Washing Buffer	FB0003139	Ambient Kit (stored at 2°C to 8°C)	Keep chilled on ice at all times. Prepare 0.5X Washing Buffer (12 mL per sample) with nuclease-free water (1:1 dilution)
Nuclease-Free Water	Customer provided	N/A	Obtain

5.3.2. Reverse Transcription

1. Add the reagents listed in the table below directly to the 5 mL tubes of PIPs.

Reagent	Volume Per Reaction (µL)
RT Additive Mix V	800
TSO	80
RT Enzyme Mix	120
Total	1000

- Mix well by flicking or tapping the bottom of the tube and pulse vortexing for 5 seconds. Briefly spin without pelleting PIPs.

Workflow Tip: *If PIPs are pelleted in centrifuge, repeat vortexing and centrifuge steps.*

- Perform cDNA synthesis with the following protocol in the PIPseq Dry Bath with the **lid open** and set to OFF.

25 °C	30 minutes
42 °C	90 minutes
85 °C	10 minutes
4 °C	Hold



- Stop Point:** The samples can be stored overnight at 4°C in the PIPseq Dry Bath or the fridge before proceeding to the next step if desired. Briefly spin down tubes before proceeding with the next step.

5.3.2. Washing PIPs with 0.5X Washing Buffer

- Prepare a 1:1 dilution of 1X Washing Buffer with nuclease-free water to make 12 mL of 0.5X Washing Buffer per sample. (At least 24 mL of 0.5X Washing Buffer for 2 samples.)
- Centrifuge the 5 mL tubes in a swinging bucket centrifuge for 2 minutes at 750 x g, using ~70-80% of the maximum braking speed to pellet the PIPs.
- Aspirate and discard supernatant to **1 mL mark on tube** without disturbing the PIPs pellet.
- Add 4 mL 0.5X Washing Buffer to each PIP tube.
- Vortex mix each PIP tube for 5 seconds.
- Centrifuge for 2 minutes on a swinging bucket centrifuge at 750 x g.
- Aspirate and discard supernatant to **1 mL mark on tube. Do not disturb the PIPs pellet.**
- Repeat steps 4-7 two more times using 4 mL of 0.5X Washing Buffer for the addition and removal steps **for a total of 3 washes.**
- Store samples on ice and proceed promptly to cDNA amplification.

Wash Checklist	
Wash 1	<input type="checkbox"/>
Wash 2	<input type="checkbox"/>
Wash 3	<input type="checkbox"/>

5.4. cDNA Whole Transcriptome Amplification

Reagent and Material Preparation			
Component Name	Part Number	Kit	Preparation
4X PCR Master Mix	FB0005099	-20°C Kit	Thaw on ice, pipette mix 10X, and centrifuge briefly
WTA Primer	FB0005091	-20°C Kit	Thaw on ice, pipette mix 10X, and centrifuge briefly
0.2 mL PCR 8-tube strip without Cap, Greiner Bio-One, 673210	FB0002076	Consumables Kit	Obtain
PCR 8-Cap strips, domed cap, Greiner Bio-One, 373270	FB0001055	Consumables Kit	Obtain

1. Add the reagents listed in the table below directly to each sample.

Reagent	Volume Per Reaction (µL)
4X PCR Master Mix	335
WTA Primer	14
Total	349

2. Mix well by vortexing for 10 seconds. Quick spin.
3. Pipette mix 10 times to resuspend before distributing the WTA reaction mixture into 8 x 168 µL aliquots in a **Greiner Bio-One 8-tube strip (FB0002076)**. Perform a quick spin prior to making the last aliquot and transfer all of the remaining volume.
4. Use a P200 multichannel pipette to transfer 56 µL from each tube into two new 8-tube strips, for **three total 8-tube strips per sample**. Do not eject tips between dispenses. Label appropriately so each sample can be recombined after cDNA amplification.

- Run the program below with the thermocycler lid set to 105°C.



WARNING: Do not change the PCR cycle number. The specified parameters are critical for assay performance, any alterations will result in unusable results.

Temperature (°C)	Time	Cycle Number
95	3 min	x1
98	15 sec	x5
69	10 min	
72	5 min	x1
4	hold	

NOTE: Annealing and extension both occur at 69°C in this WTA profile.



- Stop Point:** Samples can be stored overnight at 4°C before proceeding to the next step.

5.5. Isolate cDNA from PIPs

The remaining steps in the protocol will be performed using plasticware from a general laboratory supplier. These supplies are not included in the kit. There are multiple options for the 0.2 mL and 5 mL sample tubes used in the remaining steps, depending on your preference. These include 0.2 mL strip tubes or a PCR reaction plate (requires a plate-compatible magnetic bead rack).

Reagent and Material Preparation			
Component Name	Part Number	Kit	Preparation
CE Buffer	FB0005064	Ambient Kit	Obtain, keep room temperature
Fluent Magnetic Cleanup Beads	FB0004980	Ambient Kit (stored at 2°C to 8°C)	Warm to room temperature (at least 20 minutes before use, limit light exposure)
Nuclease-free water	Customer provided, see recommendation	N/A	Obtain, keep room temperature
IDTE Buffer, pH 8.0 (or similar low EDTA TE Buffer)	Customer provided, see recommendations	N/A	Obtain
5 mL or 15 mL tubes	Customer provided, see recommendations.	N/A	Obtain
0.2 mL strip tubes or PCR reaction plates	Customer provided, see recommendations.	N/A	Obtain
3 x 15 ml / 50 ml Magnetic Separation Combo Rack	Customer provided, see recommendations.	N/A	Obtain

5.5.1. cDNA Isolation

1. Remove Fluent Magnetic Cleanup Beads from 4 °C storage to come to room temperature for at least 20 minutes before use.
2. Add 30 µL of CE Buffer to each WTA reaction in the 0.2 mL tube strip.
3. Transfer contents of all 24 wells of each sample into one new 5 mL (or 15 mL) tube per sample.

Workflow Tip: *Centrifuge the 8-tube strips after the first transfer to ensure all beads and supernatant are completely transferred.*

4. Pulse vortex mix the WTA reactions with CE Buffer thoroughly and spin down the 5 mL tube in a swinging bucket centrifuge at 750 x g for 2 minutes, using ~70% maximum braking speed to pack the PIPs.
5. Transfer 1100 µL of the supernatant into a NEW labeled 5 mL (or 15 mL) tube per sample without disturbing the PIP pellet.
6. Add another 1700 µL of CE Buffer to the original 5 mL tube containing the PIP pellet.
7. Pulse vortex mix thoroughly and spin down the 5 mL tube in a swinging bucket centrifuge at 750 x g for 2 minutes, using ~70% maximum braking speed to pack the PIPs.
8. Carefully transfer 1700 µL of the supernatant into the 5 mL tube containing the supernatant from step 5. This will generate a total of 2800 µL supernatant from each sample.
9. Briefly centrifuge the 5 mL tube containing the supernatant and examine the bottom of the tube for PIPs. If present, transfer the supernatant once more to a new 5 mL tube.

Workflow Tip: *Measure the final volume of supernatant by pipette and adjust the magnetic bead volume used in step 3 in the next section if it is not 2800 µL.*

10. Save the remaining PIP pellet at -80°C as backup for cDNA recovery (see Section 7 Appendix I) or to use for targeted applications with the SEA kit.



WARNING: The leftover PIP pellet is the only way to recover cDNA if library preparation fails to produce sequence-quality libraries and it must be retained if planning to use for SEA kit applications.

5.5.2. Magnetic Bead Purification

1. Prepare at least 6 mL of a **fresh 85% ethanol solution** in customer-provided nuclease-free water for each reaction.
2. Resuspend the Fluent Magnetic Cleanup Beads by vortexing thoroughly (< 30 seconds) to ensure a homogeneous mixture.
3. For each 2800 µL reaction volume, add 2240 µL of Fluent Magnetic Cleanup Beads. This is a 0.8x ratio of Fluent Magnetic Cleanup Beads.

Workflow Tip: For a 0.8x ratio: measured supernatant volume * 0.8 = new magnetic bead μ L volume to add.

4. Ensure the tubes are capped tightly and vortex until thoroughly mixed and homogenous, then pulse centrifuge (~2 seconds) in a swinging bucket centrifuge at 750 x g to bring the liquid to the bottom of the tube.
5. Incubate for 5 minutes at ambient temperature.
6. Place the 5 mL tubes in the magnetic stand and bind to the magnet for 5 minutes. The magnetic beads will pellet on the side of the tube and the aqueous solution should be fully clear.

Workflow Tip: If magnetic beads do not pellet after 5 minutes there may be PIP carry over from the previous step. Leave tubes on the magnet long enough to facilitate magnetic bead separation.

7. Once the aqueous solution is clear, discard the supernatant. Do not disturb the magnetic beads.
8. Carefully wash the bound magnetic beads twice with 3 mL of 85% ethanol for 30 seconds each. Do not disturb the magnetic bead pellet.

Workflow Tip: To wash magnetic beads with 85% ethanol, carefully add 3 mL of 85% ethanol to the tube without disturbing beads, let sit for 30 seconds, and then remove the 3 mL of 85% ethanol. Repeat for two washes.

9. Remove final traces of ethanol with a P20 pipette, taking care not to disturb the magnetic beads.
10. Air dry for a **maximum** of 10 minutes with the top open to remove any residual ethanol.

WARNING: Do not overdry beads. Proceed to the next step when the magnetic beads have air dried to the point of only a slight gloss remaining, but before they show cracks. Overdrying the beads can significantly decrease elution efficiency resulting in reduced cDNA yield.



11. Remove tubes from the magnetic rack and add 162 μ L IDTE Buffer (or similar low EDTA TE Buffer). Mix the IDTE Buffer and magnetic beads by pipette mixing, ensuring that the bead pellet is fully resuspended in the IDTE Buffer.

Workflow Tip: Wash the IDTE over the magnetic bead pellet on the side of the tube until the pellet is fully washed off the tube, then pipette mix at least 10 times.

12. If necessary, do a pulse centrifuge on a swinging bucket centrifuge at 750 x g (~2 seconds) to bring the liquid to the bottom of the tube.
13. Incubate for 5 minutes at room temperature.

Workflow Tip: If bead pellets are accidentally overdried and are showing cracks, it is recommended to pipette mix frequently during this incubation to minimize sample loss.

14. Place tubes into the magnetic rack and bind to the magnet for 2 minutes.

15. Using a P200 pipette set to 40 μ L, remove 4 aliquots of 40 μ L of supernatant into separate PCR tubes. Use one PCR strip per sample and place the strip immediately on ice. This cDNA should be used as input for library preparation in Section 5.7.



16. **Do not remove the 5 mL tube from the magnet. The remaining 2 μ L of supernatant will be used for QC (Section 5.6).**



Stop Point: Store purified cDNA on ice until ready for library preparation (see Section 5.7). Alternatively, cDNA may be stored at -80°C < 72 hours. Do not store at -20°C .



WARNING: Storing cDNA in a high amplicon-contaminated area may affect the quality of your samples. Make sure your samples are well contained before storing in a -80°C freezer. Please see section 2.2 for more information.

5.6. cDNA QC

Reagent and Material Preparation			
Component Name	Part Number	Kit	Preparation
4X PCR Master Mix	FB0005099	-20°C Kit	Thaw on ice, pipette mix 10X, and centrifuge briefly
WTA Primer	FB0005091	-20°C Kit	Thaw on ice, pipette mix 10X, and centrifuge briefly
Washing Buffer	FB0003139	Ambient Kit (stored at 2°C to 8°C)	Keep chilled on ice. Prepare 0.5X Washing Buffer (14 μL per sample) with nuclease-free water.
0.2 mL strip tubes or PCR reaction plates	Customer provided, see recommendations	N/A	Obtain

5.6.1. cDNA Amplification for QC

1. Use the remaining elution volume (2 μ L) from the magnetic bead pellet (5.5.2.16) to perform this cDNA QC.
2. Keep the 5 mL tubes on the magnet.
3. Add 9 μ L of nuclease-free water into the tube with the remaining 2 μ L from the previous elution and mix well without disturbing the bead pellet.
4. Incubate on the magnet for 1 minute at ambient temperature.
5. Remove 10 μ L of the remaining cDNA without disturbing the bead pellet and transfer into a new 0.2 mL PCR strip tube. Place the sample on ice.
6. Prepare the QC master mix as described in the table below, mix briefly by vortexing, and briefly centrifuge on a benchtop minifuge to collect.

Workflow Tip: Do not exceed 10% reaction overage when creating a master mix.

Reagent	Volume Per Reaction (μL)	2.2x Reaction Master Mix (μL)
4X PCR Master Mix	6.25	13.8
WTA Primer	1	2.2
0.5X Washing Buffer	7.75	17.1
Total	15	33.1

- Add 15 μL of QC master mix into each 10 μL sample for a total reaction volume of 25 μL.
- Mix well by pulse vortexing and centrifuge briefly in a benchtop minifuge for 2 seconds to collect the reaction volume at the bottom of the tube.
- Run the program below with the thermocycler lid set to 105°C.

Temperature (°C)	Time	Cycle Number
95	3 min	x1
98	15 sec	x8-11
69	4 min	
72	5 min	x1
4	hold	

NOTE: Annealing and extension both occur at 69°C in this PCR profile.

Sample Input	Recommended Cycle Number for QC
High RNA sample types (eg: cell lines)	8
Low RNA sample types (eg: primary cells and nuclei)	11

- Stop Point:** Samples may be stored at 4°C overnight or proceed immediately to cDNA Isolation for QC (Section 5.6.2). It is recommended to **conduct QC prior to proceeding with library preparation** in order to ensure cDNA sample quality and integrity.



5.6.2. cDNA Isolation for QC

Reagent and Material Preparation			
Component Name	Part Number	Kit	Preparation
CE Buffer	FB0005064	Ambient Kit	Obtain, keep room temperature
Fluent Magnetic Cleanup Beads	FB0004980	Ambient Kit (stored at 2°C to 8°C)	Warm to room temperature (at least 20 minutes before use, limit light exposure)

Nuclease-free water	Customer provided, see recommendation	N/A	Obtain.
IDTE Buffer (Nuclease-free 1X low EDTA IDTE, pH 8.0)	Customer provided, see recommendations	N/A	Obtain
Bioanalyzer 2100 or TapeStation 4200 and Reagents	Customer provided, Agilent	N/A	Prepare according to manufacturer's recommendations, HSD5000 ScreenTape recommended for TapeStation
0.2 mL strip tubes or PCR reaction plates	Customer provided, see recommendations.	N/A	Obtain
0.2 mL / 1.5 mL Magnetic Separation Combo Rack	Customer provided, see recommendations	N/A	Obtain

1. Prepare at least 400 μL fresh 85% ethanol in nuclease-free water per reaction.
2. Dilute the PCR reaction to 40 μL by addition of 15 μL nuclease-free water.
3. For 40 μL reaction volumes: add 32 μL Fluent Magnetic Cleanup Beads to samples in the PCR strip. This is a 0.8x ratio of Fluent Magnetic Cleanup Beads. Use a new lid to seal the 8-tube strip.
4. Mix thoroughly by pipetting up and down 15 times at 67 μL stroke..
5. Incubate for 5 minutes at room temperature.
6. Place tubes into the magnetic rack and bind to the magnet for 5 minutes.
7. Once the aqueous solution is clear, discard the supernatant being careful not to touch the magnetic beads.
8. Carefully wash twice with 200 μL 85% ethanol for 30 seconds each. Do not disturb the magnetic bead pellet.
9. Remove final traces of ethanol with a P20 pipette, taking care not to disturb the magnetic beads.
10. Air dry for a maximum of 5 minutes with the top open to remove any residual ethanol, taking care not to overdry. The magnetic beads should still look glossy, not cracked.



WARNING: Do not overdry beads. Proceed to the next step when the magnetic beads have air dried to the point of only a slight gloss remaining, but before they show cracks. **This can take as few as 2 minutes depending on the humidity level. Overdrying the beads can significantly decrease elution efficiency resulting in reduced cDNA yield.**

11. Remove tubes from the magnetic rack and add 11 μL IDTE Buffer, pH 8.0 (or similar low EDTA TE Buffer). Mix the IDTE Buffer and Fluent Magnetic Cleanup Beads by pipette mixing, ensuring that the bead pellet is fully resuspended in the IDTE Buffer.

Workflow Tip: Wash the IDTE Buffer over the magnetic bead pellet on the side of the tube until the pellet is fully washed off the tube, then pipette up and down at least 10 times.

12. If necessary, do a pulse centrifuge on a benchtop minifuge.
13. Incubate for 5 minutes at room temperature.

Workflow Tip: If bead pellets are accidentally overdried and are showing cracks, it is recommended to pipette mix frequently during this incubation to minimize sample loss.

14. Place tubes into the magnetic rack and bind to the magnet for 2 minutes.
15. Remove and SAVE 10 μ L of supernatant in a new PCR tube strip for QC.



WARNING: Do not use QC product as input into library preparation. This will result in unusable results.

5.6.3. Qubit Quantification

1. Using a Qubit High Sensitivity kit, quantify 2 μ L of each sample according to the manufacturer's instructions.

5.6.4. Fragment Analysis

1. Users may use an Agilent BioAnalyzer or TapeStation. Dilute samples if necessary to ensure they are within the appropriate range of the device.
2. Load an appropriate volume of the purified library on the fragment analyzer. Recommended loading concentration is 1-10 ng/uL on TapeStation and 1-2 ng/uL on Bioanalyzer (Figure 8). Loading less than 1 ng/uL may not give accurate results.
3. **Proceed to library preparation upon successful cDNA QC.** The average fragment size for cDNA should be over 500 bp as determined by the fragment analyzer region table (set for 200 - 5k bp). Average size may vary depending on cell type and experimental condition.

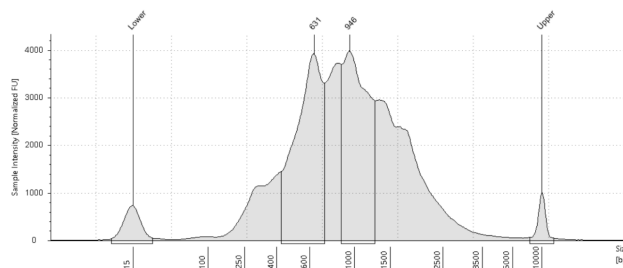

Figure 8. Representative cDNA traces for a 40,000 cell input human/mouse cell mixture (HEK 293T/NIH 3T3) using a **high sensitivity D5000 ScreenTape**.

5.7. Library Preparation

Reagent and Material Preparation			
Component Name	Part Number	Kit	Preparation
Fluent Magnetic Cleanup Beads	FB0005079	Library Ambient Kit (stored at 2°C to 8°C)	Warm to room temperature (at least 20 minutes before use, limit light exposure)
Nuclease-free water	Customer provided, see recommendation	N/A	Obtain and use to dilute the EtOH in the magnetic-bead purification step
TE Buffer, pH 8.0	Customer provided, see recommendations	N/A	Obtain
Library Prep Buffer	FB0005080	Library -20°C Kit	Thaw on ice, vortex for 5 seconds, briefly centrifuge, store on ice
Library Prep Enzymes	FB0005081	Library -20°C Kit	Thaw on ice, pipette mix, briefly centrifuge, store on ice
Library Prep Mix A	FB0005082	Library -20°C Kit	Thaw on ice, pipette mix, briefly centrifuge, store on ice
Library Adapter Mix	FB0005083	Library -20°C Kit	Thaw on ice
Nuclease-free water	FB0005085	Library Ambient Kit	Obtain and use to dilute Library Adapter mix and to elute during the Post Ligation Cleanup
4X PCR Master Mix	FB0005084	Library -20°C Kit	Thaw on ice, pipette mix, briefly centrifuge, store on ice
UDI Library Index Mix Strip	FB0005121	Library -20°C Kit	Thaw on ice

5.7.1. Fragmentation, End Repair & A-Tailing



WARNING: It is critical to use the total 160 µL volume of cDNA recovered in section 5.5.2. for library preparation for optimal assay performance. See Appendix I - cDNA reamplification for troubleshooting options if library preparation is unsuccessful.

Due to the high number of cells loaded per sample, it is required to prepare 4 separate libraries for each T100 reaction with different index combinations to increase sequencing diversity and improve sequencing quality.

1. Obtain the 4x40 µL of cDNA (8-strip tube) generated in section 5.5.2.15 and place on ice.
2. Pre-chill the thermocycler with the program in step 6, to hold at 4°C or chill to 4°C in the time it will take to prepare the reactions (~10 minutes) with the heated lid set to 105°C.
3. Create a master mix of the Library Prep Buffer and Enzymes according to the table below. Homogenize by vortexing at a moderate intensity (avoid bubbling) for 5 seconds, and briefly centrifuge on a benchtop minifuge.

Workflow Tip: Add 10% reaction overage when calculating volumes for the master mix to account for standard pipetting error.

Reagent	Volume Per Sample (µL)	4.4x Reaction Mastermix (µL)	8.8x Reaction Mastermix (µL)
Library Prep Buffer	4	17.6	35.2
Library Prep Enzymes	6	26.4	52.8
Total	10	44	88

- Add 10 µL of the master mix from step 3 to each 40 µL cDNA sample for a total reaction volume of 50 µL as shown in the table below.

Reagent	Volume Per Sample (µL)
cDNA	40
Library Master Mix	10
Total	50

- Vortex the samples at a moderate intensity for 5-10 seconds to homogenize (avoid bubbling), and briefly centrifuge to collect. Keep samples on ice!



WARNING: Complete mixing is crucial; users may vortex or pipette mix 10 times at the 25 µL stroke.

- Place samples in the thermocycler with the 4°C block and 105°C lid at the designated temperatures. Use the 'skip step' function on the thermocycler to start the 30°C step and run the program below.

Temperature (°C)	Time
4	HOLD
30	6 min
65	30 min
4	HOLD

Workflow Tip: During this incubation prepare the Library Adapter Mix dilution according to the next section and place it on ice.

- Proceed immediately to Adapter Ligation after the program has finished and the samples have returned to 4°C.

5.7.2. Adapter Ligation

- Prepare a dilution of the Library Adapter Mix (100 µM) to a final concentration of 15 µM using the nuclease-free water provided in the kit as described in the table below. Prepare enough diluted Library Adapter Mix for all 4 reactions per T100 sample.

Reagent	Volume Per Sample (µL)	4.4x Reaction Master Mix (µL)	8.8x Reaction Master Mix (µL)
Library Adapter Mix	0.75	3.3	6.6
Nuclease-free water	4.25	18.7	37.4
Total	5	22	44



WARNING: Store dilutions of the Library Adapter Mix for less than 1 week at -20°C.

- Remove the samples from the thermocycler immediately upon return to 4°C.
- Add 5 µL of diluted Library Adapter Mix to each reaction, mix thoroughly by brief vortexing or pipetting, and briefly centrifugation to collect at the bottom of the tube.
- Pipette mix (do not vortex)** Library Prep Mix A 15 times at the 130 µL stroke to homogenize and place on ice.
- Add 20 µL of Library Prep Mix A to each sample for a total reaction volume of 75 µL.

WARNING: Library Prep Mix A is viscous, pipette slowly to ensure proper volumes are dispensed.



- Pipette mix the reactions 10 times at the 40 µL stroke, and briefly centrifuge to collect.
- Place samples in the thermocycler and run the program below (20°C for 20 min), with the heated lid OFF.

Temperature (°C)	Time
20	20 min

- Proceed immediately** to the Post Ligation Cleanup.

5.7.3. Post Ligation Cleanup

1. Prepare at least 400 μL of a **fresh 85% ethanol solution** in customer-provided nuclease-free water for each reaction.
2. Resuspend the Fluent Magnetic Cleanup Beads by vortexing thoroughly (<30 seconds) to ensure a homogeneous mixture.
3. Remove the ligation reaction from the thermocycler.
4. Add 60 μL (0.8x) of resuspended Fluent Magnetic Cleanup Beads to each sample in the PCR strip. Mix thoroughly by pipetting up and down 15 times at 125 μL stroke.
5. Incubate samples at room temperature for 5 min.
6. Place the PCR strip into the magnetic rack and bind beads to the magnet for 5 minutes, until the solution is clear and all beads have collected on the tube wall.
7. Remove and discard the supernatant from each tube ($\sim 135 \mu\text{L}$), being careful to not disturb the beads.
8. Carefully wash beads twice with 200 μL of 85% ethanol for 30 seconds each.

WARNING: Do not disturb beads. Add 85% ethanol slowly, let stand for 30 seconds, and remove the full volume of 85% ethanol keeping the pipette tip away from the bead pellet.



9. Remove any final traces of ethanol with a P20 pipette without disturbing beads.
10. Air dry beads for a **maximum** of 5 minutes with the top open. **Do not overdry.**
Workflow Tip: The beads should still look glossy, not cracked. This can take as few as 2 minutes depending on the humidity level.
11. Remove tubes from the magnetic rack and add 34 μL of the nuclease-free water provided in the kit.
12. Pipette mix to thoroughly resuspend the Fluent Magnetic Cleanup Beads in nuclease-free water at least 10 times at the 32.5 μL stroke.
Workflow Tip: Wash the water over the bead pellet on the side of the tube until the pellet is fully washed off, then pipette mix at least 10 times.
13. Incubate tubes at room temperature for 5 min.
14. Place tubes into the magnetic rack and bind to the magnet for 2 min, or until the solution is clear.
15. Carefully transfer 32.5 μL of each library-containing supernatant to a new 0.2 mL PCR tube strip.

5.7.4. Sample Index PCR

Choose and record a unique index mix for each sample to ensure no sample index combinations overlap in a multiplexed sequencing run. Be sure to align the orientation of the hole on the side of the strip containing the indices with the index map in the box lid and in the diagram below. Pierce the foil with a P20 pipette before aspirating.



CRITICAL: Check orientation of index strip tube to ensure the correct index combination is added and recorded for sequencing.

There are 8 index mixes provided with this kit to allow for unique dual indexing of 2 T100 samples. To pool more than 2 T100 PIPseq libraries together in a sequencing run, ask about the PIPseq UDI-96 Kit (FBS-UDI-96).

1. Thaw 4X PCR Master Mix on ice. Once thawed, flick the tubes several times, **pipette mix 10 times (do not vortex)**, and then briefly centrifuge to collect.
2. To the 32.5 μL of each cleaned library, add the following *individually*, in the order in which they appear in the table below.

Reagent	Volume Per Sample (μL)
Cleaned library DNA	32.5
Unique UDI Library Index Mix	5.0
4X PCR Master Mix	12.5
Total	50

3. Pipette mix the reactions 10 times at the 32 μL stroke, and briefly centrifuge to collect.
4. Place samples in the thermocycler and run the program below, with the heated lid set to 105°C.

Temperature ($^{\circ}\text{C}$)	Time	Cycles
98	45 sec	x1
98	15 sec	x9-13
67	30 sec	
69	45 sec	
72	1 min	x1
4	Hold	Hold

Workflow Tip: The number of sample index PCR cycles should be optimized for a given sample type. Starting recommendations based on general RNA content of cell types are provided below. If the cDNA QC concentrations were high (over 200 ng/μL), consider decreasing by 1 - 2 cycles.

Library Preparation DNA Input (ng)	Recommended Sample Index PCR Cycles
High RNA sample types (eg: cell lines)	9
Low RNA sample types (eg: primary cells and nuclei)	13



- Stop Point:** Samples may be stored at 4°C overnight or proceed immediately to Post Sample Index PCR Cleanup.

5.7.5. Post Sample Index PCR Cleanup (one-sided)

- Prepare at least 400 μL of **fresh 85% ethanol solution** in customer-provided nuclease-free water per reaction.
- Resuspend the Fluent Magnetic Cleanup Beads by vortexing thoroughly (<30 seconds) to ensure a homogeneous mixture.
- Dilute the PCR reaction to 95 μL by addition of 45 μL customer-provided nuclease-free water.
- For 95 μL reaction volumes, add 76 μL Fluent Magnetic Cleanup Beads. This is a 0.8x ratio of magnetic beads. Adjust as necessary if reaction volume is not 95 μL. Use a new lid to seal the 8-tube strip.
- Mix thoroughly by pipetting up and down 15 times at a 160 μL stroke and incubate for at least 5 minutes at room temperature.
- If necessary, do a final pulse centrifuge of the beads.
- Place tubes onto the magnetic rack and bind for 5 minutes.
- Discard the supernatant.** Be careful not to disturb the magnetic beads.
- Carefully wash twice with 200 μL of 85% ethanol for 30 seconds each. Do not disturb the magnetic beads.
- Remove final traces of ethanol with P20 pipette being careful not to disturb the magnetic beads.
- Air dry for a **maximum** of 5 minutes with the top open to remove any residual ethanol.



WARNING: Do not overdry beads. Proceed to the next step when the magnetic beads have air dried to the point of only a slight gloss remaining, but before they show cracks. This can take as few as 2 minutes depending on the humidity level.

12. Remove tube from the magnetic rack and add 21 of μL IDTE Buffer (pH 8.0). Pipette mix the IDTE Buffer and magnetic beads at least 10 times at the 20 μL stroke.
13. Incubate for 5 minutes at room temperature.
14. If necessary, do a pulse centrifuge of the magnetic beads.
15. Place tubes onto the magnetic rack and bind to the magnet for 2 minutes.
16. Remove and **SAVE** 20 μL of supernatant in a new PCR tube strip.
17. **Stop Point:** Samples can be stored at -20°C long-term.



5.8. Post Library Preparation QC

Reagent and Material Preparation			
Component Name	Part Number	Kit	Preparation
Qubit Fluorometer and Reagents	Customer provided, ThermoFisher	N/A	Prepare according to manufacturer's recommendations
Bioanalyzer 2100 or TapeStation 4200 and Reagents	Customer provided, Agilent	N/A	Prepare according to manufacturer's recommendations, HSD1000 ScreenTape recommended

5.8.1. Qubit Quantification

1. Using a Qubit High Sensitivity kit, quantify 2 μL of each sample according to the manufacturer's instructions.

5.8.2. Fragment Analysis

1. Users may use an Agilent BioAnalyzer or TapeStation. Dilute samples if necessary to ensure they are within the appropriate range of the device.
2. Load an appropriate volume of the purified library on the fragment analyzer. Recommended loading concentration is 1-10 ng/uL on TapeStation or 1-2 ng/uL on Bioanalyzer. (Figure 9).

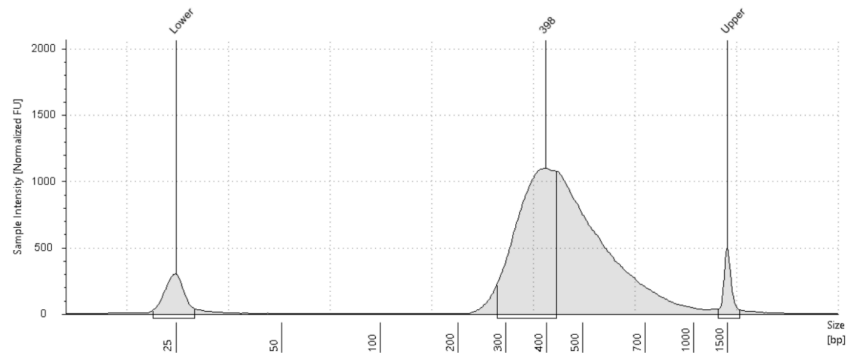
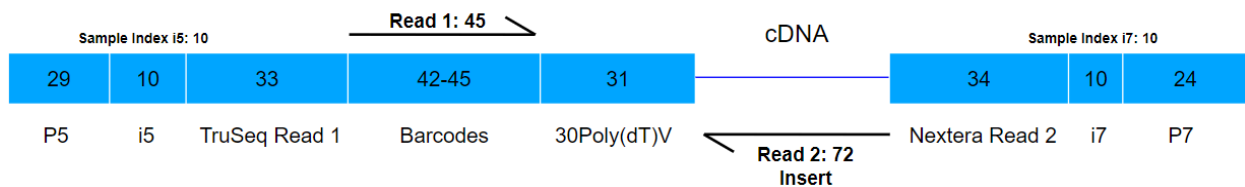

Figure 9. Representative library trace (expected avg. size 400-550 bp) for a 40,000 cell capture HEK/3T3 cell mixture on a **High Sensitivity D1000 ScreenTape** (above).

6. Sequencing

6.1. Library Structure

PIPseq V T100 3' Single Cell gene expression libraries are composed of standard Illumina paired-end constructs that begin with P5 and end with P7. Read 1 contains the barcode information while Read 2 contains the gene expression information. These libraries are dual-indexed with 10-base i5 and i7 indexes. Read 1 length must be ≥ 45 bases and the recommended read 2 length ≥ 72 bases. It is recommended to maximize the use of the flow cell with longer reads when possible.



6.2. Recommended Sequencing Depth

Sequencing depth will vary based on your application needs but it is recommended to start with a depth of 20,000 reads per input cell. After sequencing, users may evaluate the Sequencing Saturation metric output from PIPseeker software to optimize sequencing depth for specific sample types. Users are referred to the FB0002787 PIPseeker User Guide for more information.

6.3. Sequencer Compatibility

The sequencing instruments below have been verified as compatible with PIPseq by Fluent BioSciences. Some variation in assay performance may be experienced on distinct sequencing platforms.

- MiSeq
- NextSeq 550

- NextSeq 2000
- NovaSeq 6000
- NovaSeq X

Long read sequencing technologies can be used for sequencing PIPseq libraries; however, Fluent does not currently provide support for these applications.



WARNING: It is important to make sure no quality trimming or adapter trimming is used when converting BCL files into FASTQ files. When using a sample sheet, be sure that no adapter reads are listed under “Adapter”, “AdapterRead1”, or “AdapterRead2”.

6.4. Pooling for Illumina Sequencers

PIPseq 3' Single Cell gene expression libraries may be pooled for sequencing, taking into account the differences in cell number and read depth requirements. Samples must have distinct index combinations to avoid failures in sample demultiplexing. Refer to Illumina documentation for discussion of appropriate color balance combinations for the selected sequencing platform. Once quantified and normalized, the PIPseq 3' gene expression libraries should be diluted and prepared as recommended in Illumina documentation for the selected Illumina sequencing platforms. PIPseq libraries require a minimum of **1% PhiX** to be added to the loaded library pools. It is recommended to increase PhiX to a minimum of **2%** with NovaSeq X series sequencers.

6.5. Informatics Analysis

Fluent provides the PIPseeker™ software for analysis of single cell RNA data obtained with Fluent BioSciences' PIPseq V 3' Single Cell RNA (scRNA-seq) Kits. PIPseeker offers a comprehensive analysis solution that provides the user with detailed metrics, gene expression profiles, basic cell quality and clustering indicators, and cell type annotation for some sample types. PIPseeker also supports specialized analysis workflows enabled by Fluent's SEA V Kit (FB0005376). Additionally, the filtered matrix outputs of PIPseeker can be used for specialized tertiary analysis streams at the discretion of the user.

Visit <https://www.fluentbio.com/products/pipseeker-software-for-data-analysis/> to download the latest PIPseeker v3.3 or later software.



WARNING: PIPseq V chemistry kits are only compatible with PIPseeker v3.3 or later analysis software. Analysis of single cell data generated using PIPseq V 3' Single Cell RNA Kits using PIPseeker 2.x or 1.x analysis software will result in compromised performance.

6.6. PIPseq 3' Index Sequences

Part Number	Component Name	i7 sequence (for sample sheet)	i7 adapter sequence	i5 adapter sequence
FB0005121	UDI Library Index mix 1	GAGAATGGTT	AACCATTCTC	TCGGCAGCAA
	UDI Library Index mix 2	TAGAATTGGA	TCCAATTCTA	CTAATGATGG
	UDI Library Index mix 3	CCATCATTAG	CTAATGATGG	GGTTGCCTCT
	UDI Library Index mix 4	GATAGGCCGA	TCGGCCTATC	CGCACATGGC
	UDI Library Index mix 5	ATGGTTGACT	AGTCAACCAT	GGCCTGTCCT
	UDI Library Index mix 6	TATTGCGCTC	GAGCGCAATA	CTGTGTTAGG
	UDI Library Index mix 7	ACGCCTTGTT	AACAAGGCGT	TAAGGAACGT
	UDI Library Index mix 8	TTCTACATAC	GTATGTAGAA	CTAACTGTAA

7. Appendix I - PIPseq Replay with the SEA Kit

If library preparation fails to generate sequence-quality libraries from QC passed cDNA (as assessed at cDNA fragment analysis, see section 5.6.4), users may choose to generate a second batch of cDNA using the PIP pellet that was saved at -80 °C. This optional step is presented as a recovery method but requires the use of materials provided in the Fluent SEA V Kit (FB0005376) to generate a new batch of cDNA and the materials provided in the Fluent PIPseq V Library Prep Kit (FB0005372) to prepare a sequencing-ready library from the recovered cDNA. Refer to the appropriate section in the FB0005446 PIPseq Replay User Guide for instructions.





8. Appendix II - Oligonucleotide Sequences

Part Number	Name	Sequence (5' - 3')
Pre-mixed with i5	i7 Index	CAAGCAGAAGACGGCATAACGAGATXXXXXXXXXX GTCTCGTGGGCTCGGAGATGTGTATAAGAGACAG
Pre-mixed with i7	i5 Index	AATGATACGGCGACCACCGAGATCTACACXXXXX XXXXXACACTCTTTCCCTACACGACGC
FB0005091	WTA Primer	Forward: CTCTTTCCCTACACGACGCTC Reverse: AAGCAGTGGTATCAACGCAGAGT
FB0005109	TSO	AAGCAGTGGTATCAACGCAGAGTGAATrGrGrG
FB0005083	Library Adapter Mix	Ligation primer: /5Phos/CTGTCTCTTATACACATCTCCGAGCC Ligation adapter: TATAAGAGACAGT

9. Appendix III - Abbreviations

PIPs	_____	Particle-templated Instant Partitions
RNA	_____	Ribonucleic Acid
DNA	_____	Deoxyribonucleic Acid
dsDNA	_____	Double-Strand DNA
cDNA	_____	Complementary DNA
TSO	_____	Template Switch Oligo
WTA	_____	Whole Transcriptome Amplification
RPM	_____	Revolutions Per Minute

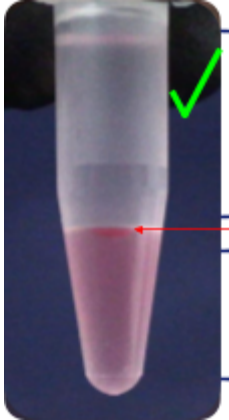
10. Appendix IV - Troubleshooting

STEP	NORMAL	ABNORMAL
<p>5.2.2.2 Removal of Partitioning Reagent to below #2 (or “A”) line</p>	 <p>Top of the emulsion must be at or below 2 line</p>	 <p>Top of the emulsion remains above the 2 line</p>
<p>5.2.2.6 Two distinct phases and a homogenous opaque upper phase indicating complete breaking</p>	 <p>PIPs to be kept</p> <p>Red droplet to be removed Pink waste</p>	 <p>Heterogeneous opaque upper phase, which might also show bubbles or a non-distinct red droplet at the interphase, may indicate unbroken emulsion</p>

11. Document Revision Summary

Doc ID: **FB0005262**

Revision: **1.5**

Revision date: **September 2024**

Specific Changes:

- Recommendation added to prepare Reagents and Materials for Capture and Lysis prior to starting sample preparation and added clarification on the PCR unidirectional workflow
- Further clarification added to make sure customers are using low EDTA TE Buffer (IDTE)
- Updated Sample Index PCR starting point recommendations for low RNA content cycle number
- Fixed sequence error in i7 sequence for sample sheet of UDI-3

12. Legal Notices

© 2024 *Fluent BioSciences, Inc (Fluent BioSciences)*. All rights reserved. Duplication and/or reproduction of all or any portion of this document without the express written consent of *Fluent BioSciences*, is strictly forbidden. Nothing contained herein shall constitute any warranty, express or implied, as to the performance of any products described herein. Any and all warranties applicable to any products are set forth in the applicable terms and conditions of sale accompanying the purchase of such product.

Fluent BioSciences may refer to the products or services offered by other companies by their brand name or company name solely for clarity, and does not claim any rights in those third party marks or names. The use of products described herein is subject to *Fluent BioSciences* End User License Agreement, available at www.fluentbio.com/legal-notice, or such other terms that have been agreed to in writing between *Fluent BioSciences* and the user. All products and services described herein are intended **FOR RESEARCH USE ONLY** and **NOT FOR USE IN DIAGNOSTIC PROCEDURES**.

Support

Email: support@fluentbio.com



Fluent BioSciences
150 Coolidge Avenue
Watertown, MA 02472